



Wel Sprint

Swing Door Automations



LISTED
ANSI/UL 325



Swing Door Automations

Swing doors to be automated may all seem alike, and yet they have different operating requirements. DITEC offers 5 different automation models.

Product Range

	Wel E	Wel M	Wel S	Wel F	Sprint
Swing door automations	motor opening, spring closing	motor opening and closing	motor opening, spring closing	motor opening, spring closing	motor opening and closing
Special use	disabled use	disabled use emergency exits	disabled use emergency exits	fireproof doors	disabled use
Duty class	very heavy	very heavy	very heavy	heavy	very heavy

Technical Specifications

	Wel E	Wel M	Wel S	Wel F	Sprint
Capacity	100 kg x 1 m 80 kg x 1.2 m	250 kg x 1 m 150 kg x 1.5 m	250 kg x 1 m 150 kg x 1.5 m	class 5: 100 kg x 1.25 m class 6: 120 kg x 1.4 m	100 kg x 1 m 80 kg x 1.2 m
Intermittent operation	S2 = 30 min - S3 = 80%	S2 = 30 min - S3 = 80%	S2 = 30 min - S3 = 80%	S2 = 30 min - S3 = 80%	S2 = 30 min - S3 = 80%
Power supply	230 V- / 50-60 Hz	230 V- / 50-60 Hz	230 V- / 50-60 Hz	230 V- / 50-60 Hz	230 V- / 50-60 Hz
Insulation class	class 1	class 1	class 1	class 1	class 2
Input	1 A	1 A	1 A	1 A	0.2 A
Opening time	2÷10 s/90°	1.5÷5 s/90°	1.5÷5 s/90°	1.5÷5 s/90°	3 s/90°
Operating temperature	-20°C / +55°C (+5°C / +40°C with batteries)	-20°C / +55°C (+5°C / +40°C with batteries)	-20°C / +55°C (+5°C / +40°C with batteries)	-20°C / +55°C	-20°C / +55°C (+5°C / +40°C with batteries)
Protection rating	IP 31	IP 31	IP 31	IP 31	IP 12D
Product dimensions	105x128x600 105x128x830 (with batteries)	105x128x600 105x128x830 (with batteries)	105x128x600 105x128x830 (with batteries)	105x128x830	80x90x450
Type approvals	ARL listing for compliance with ANSI/UL 325 Standard (WEL EU)	TÜV, ARL listing for compliance with ANSI/UL 325 Standard (WEL MU)	TÜV, ARL listing for compliance with ANSI/UL 325 Standard (WEL SU)	TÜV - DIBt	--
Control panel	EL12	99	99 + Brake	99 + Brake + Fire	165

Wel

New, fully featured, sturdy, versatile and quiet. Packed with features.

Wel is the new automation for automatic swing doors.

Designed to offer a versatile and fully featured solution, this automation boasts a set of distinctive features, allowing it to be used in a wide range of operating conditions:

- opened and closed by a motor;
- opened by a motor and closed by a spring;
- on emergency exits;
- on fireproof doors;
- low energy for disabled access.

Sturdy, hard wearing and quiet, it is ideal for very heavy duty applications.

The automation boasts a new and smart design and very clean lines.

Wel complies with the strictest European and American standards.



LISTED
ANSI/UL 325





PUSH AND GO
A light push is all that is needed to automatically open the door

LOW ENERGY
Opens and closes doors with reduced energy and speed

Product Applications and Range

This automation is available in four different versions: E, M, S and F.

Wel M

Sturdy and versatile, ideal for very heavy duty applications.

A must in all demanding environmental conditions, such as external doors exposed to the wind and to the elements.

Wel E and Wel S

Practical, reliable and quiet. Packed with features.

To make sure the door is closed even in the event of power failure, it is advisable to select an automation opened by a motor and closed by a spring, preferably motor-assisted, such as Wel S. This solution allows the door to be manually opened and closed by a spring.

Sturdy, reliable and quiet, these automations have been designed to offer a versatile and fully featured product, suitable for heavy duty applications, even with very heavy door wings. Wel S uses the Brake system to control the closing and approaching speed even in the event of power failure. Wel E is not fitted with a Brake system, but features a simplified version, still able to control the closing operation.

Wel F

For heavy duty applications. For fireproof doors.

WEL F automation can be used on fireproof doors. For doors opening outwards, on the actuator side, the automation features an articulated arm.

Unique Facilities and Features

The new Wel offers a wide range of electronic, mechanical and special facilities to ensure its suitability for different operational requirements.

Electronic facilities

Automatic facilities:

- thrust limiter;
- obstacle detector with adjustable thrust.

Operating modes:

- Push and Go;
- electrically operated lock control modes:
 - normal mode (working current or "fail secure" - wing remains shut even in the event of power failure);
 - anti-panic mode (idle current or "fail safe" - wing remains shut only if power is available. In the event of faults or power failures, users can still exit the room);
- electrically operated lock latching control: the operating speed may be increased when approaching the electrically operated lock to ensure correct latching operation;
- electrically operated lock release control: an option may be enabled to ensure that the electrically operated lock is correctly released;
- wind-proof facility.

Wel release system may be controlled by using the TEL2 or DMCS remote control. The automation can therefore be adapted to different types of existing locks, to the features of the door (weight - strength - opening problems) or to environmental conditions (different indoor-outdoor pressures).

Wel E is a "simplified" product and therefore does not include the facilities listed below: obstacle detector with adjustable thrust, lock type control (Wel E only controls the normal lock) and electrically operated lock release control.

For light to medium weight doors, the Wel E is a simpler and more cost effective alternative to version Wel S. Wel automation features a FA limit switch, which allows the following operations to be carried out:

WEL S, WEL M, WEL F: The limit switch is used to control the wing opening angle or, by changing the connection, to bypass safety devices for the last opening section. Using the FA limit switch is optional therefore, if the automation is fitted with a door stop and does not open towards a wall, its use is not required. For applications where the wing opens towards a wall, the limit switch bypasses the operation of the sensors mounted on the wing so that they "do not see" the wall as an obstacle.

WEL E: This version does not feature an encoder; the FA limit switch is therefore used to slow down the opening action, regardless of whether a door stop is fitted or not.

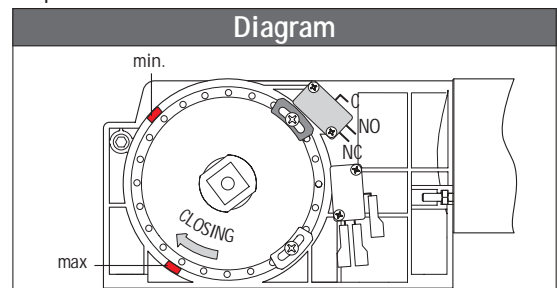
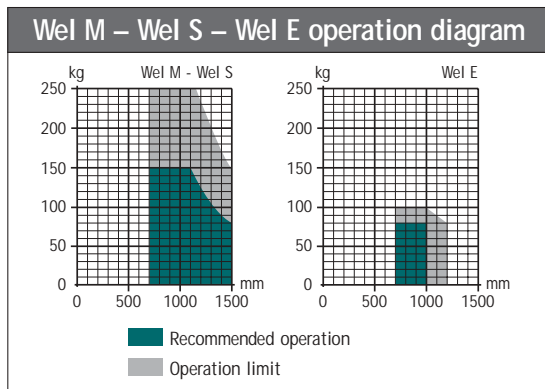
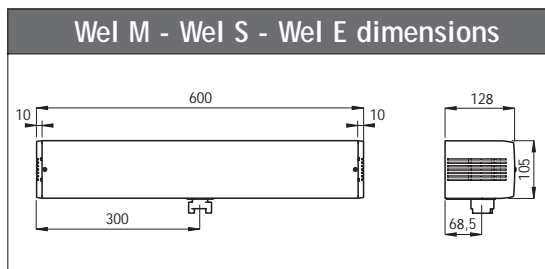

Mechanical facilities

- Three different arms may be fitted: articulated, sliding or three-section (see accessories). The type of arm used may be selected from the electronic control panel, to ensure optimal operation in all conditions (with the exception of the Wel E version);
- the spring can be easily adjusted through the screw located on the front of the automation;
- the closing speed can be adjusted even in the event of power failure by means of the Brake system PCB;
- symmetrical automation to simplify installation;
- guard extension head to fully cover the opening if the following accessories are added: batteries, fireproof door or double automation control PCB (with the exception of the Wel E version).

Special facilities

- Low energy;
 - fireproof;
 - emergency exits – being certified to DIN 18650 standard, it may be fitted to emergency exits.
- The automation features a reversible reduction unit to allow manual operation in the event of power failure.

Specific Accessories

WEL BA: Articulated arm for doors which open outwards, actuator side.

WEL BS: Sliding arm for doors which open inwards, actuator side.

WEL BRAS: Three-section articulated arm for doors which open inwards, actuator side.

WEL BSS: Break-out sliding arm, to break out the wing from the opposite side to the normal opening side. In emergencies, the arm allows door break-out towards the opposite side to the normal opening side, i.e. towards the outside of the wing.

WEL TP: Head fitted with pushbuttons.
Note - WEL TP may be used instead of the COM E-H-K selector switches.

WEL TI: Guard extension kit to fully cover the opening. The kit consists of two small heads which act as a blanking casing between two automations. After cutting the aluminium profiles to the required size to blank the opening, the heads can be used to allow the blanking casing to be connected to the automations.

WEL BAT: Battery kit to operate the automation in the event of power failure. The automation features the same covering profile and may be fitted either on the motor or control panel side by using the extension small head.

KIT WEL D40: Spacer H 40 mm for operating arms.

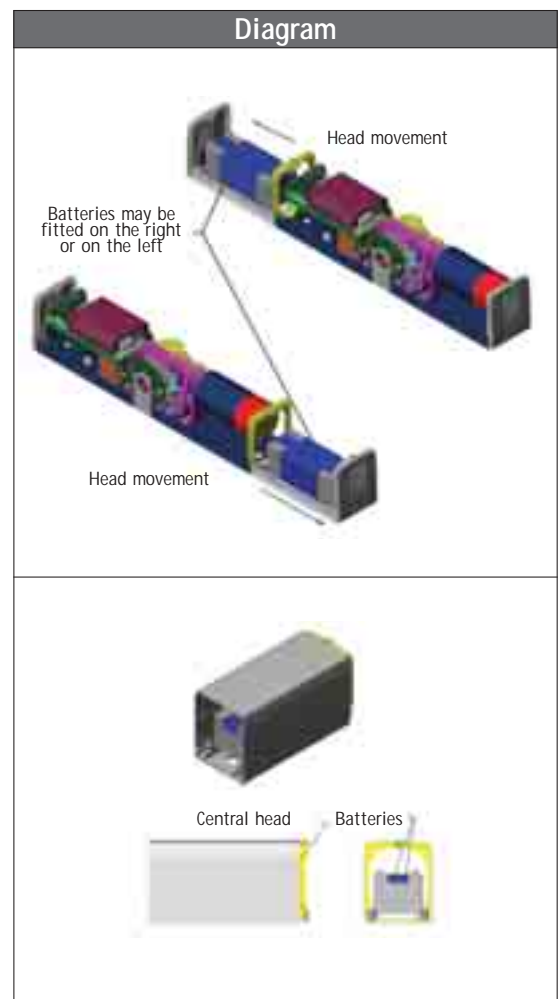
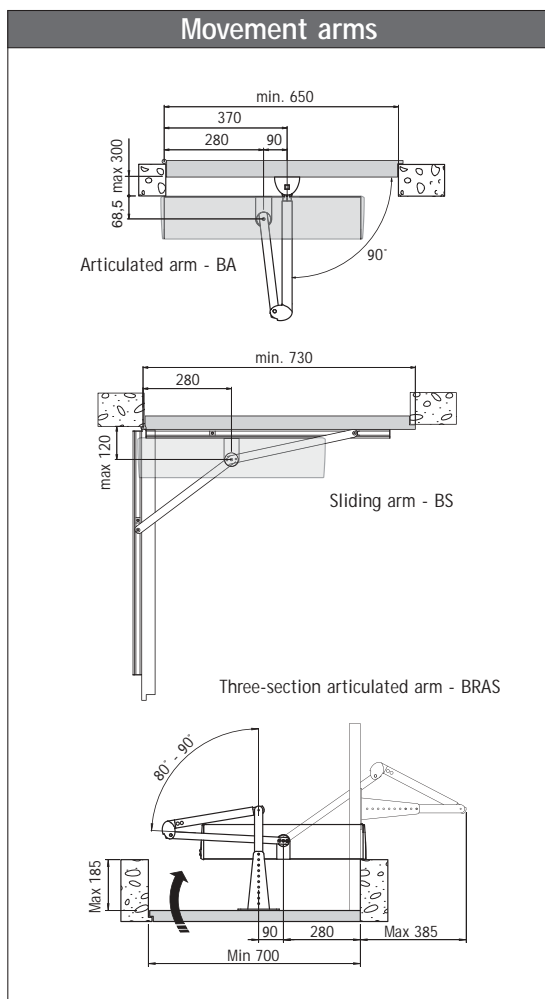

▶ Main System and Control Panel Functions

	Wel E EL12	Wel M 99	Wel S 99 + Brake	Wel F 99 + Brake + Fire	Sprint 165
Control panel					
Description	for 1 motor 24VDC	for 1 motor 24VDC	for 1 motor 24VDC	for 1 motor 24VDC	for 1 motor 12VDC
Mains power supply	230 V~ /50-60 Hz	230 V~ /50-60 Hz	230 V~ /50-60 Hz	230 V~ /50-60 Hz	230 V~ /50-60 Hz
Batteries (ensure automation operation in the event of power cuts)	✓ (optional)	✓ (optional)	✓ (optional)		✓
Number of motors	1	1	1	1	1
Motor power supply	24 V= / 6 A	24 V= / 8 A	24 V= / 8 A	24 V= / 8 A	12 V= / 5 A
Accessories power supply	24 V= / 0.3 A	24 V= / 0.5 A	24 V= / 0.5 A	24 V= / 0.5 A	24 V= / 0.15 A
Electrically operated lock	24 V= / 1.2 A	24 V= / 1.2 A	24 V= / 1.2 A	24 V= / 1.2 A	12 V= / 1.2 A
Limit switch provision	✓	✓	✓	✓	
Encoder (controls speed and deceleration)		✓	✓	✓	✓
Force adjustment	automatic	electronic	electronic	electronic	automatic
ODS – Obstruction detection system (causes the automation to stop or reverses operation when an obstruction is detected)		✓	✓	✓	✓
Speed adjustment	✓	✓	✓	✓	✓
Braking / Slowdown control (ensures best approach)	✓	✓	✓	✓	
Open control	✓	✓	✓	✓	✓
Push opening - PUSH & GO	✓	✓	✓	✓	✓
Close control	✓	✓	✓	✓	✓
Automatic timed close control	✓	✓	✓	✓	✓
Stop safety device	✓	✓	✓	✓	✓
Reserve operation safety device	✓	✓	✓	✓	✓
Safety test facility		✓	✓	✓	

▶ Sprint

▶ **Small in size. Big in performance.**
Ideal for residential use.

Compact and light automation, ideal for residential use.

It is supplied with a back-up battery, located inside the automation, and with an ON/OFF switch, located in an easily accessible position.

Ensures an easy and practical access.

The automation also allows the user to select the Low Energy and Push and Go modes.

The Low Energy facility allows the door to be opened and closed with reduced energy and speed, making the Sprint automation particularly suitable for less able bodied users. The Push and Go facility, also supplied as standard, is essential when automatic opening enabled by an initial manual push is required.

▶ **Practical, safe and reliable**

Sprint features a standard anti-crushing device, which makes it safer and more reliable, as it can be manually operated even in the event of power failure. These and other unique features make Sprint one of the world's leading automations for swing doors for residential use.

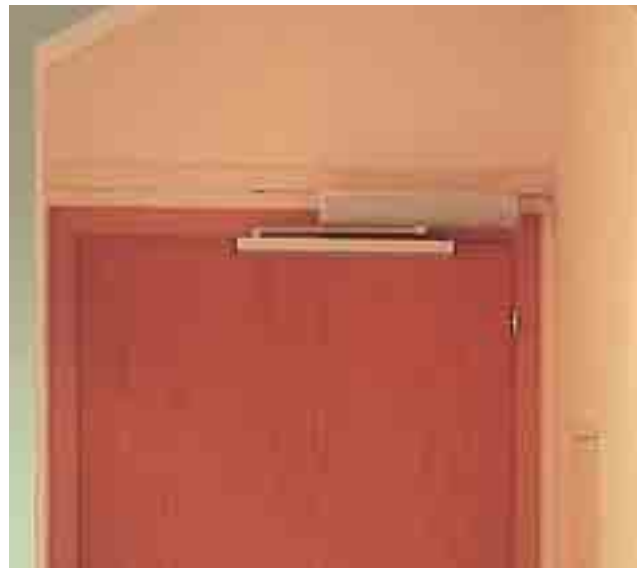

PUSH AND GO

A light push is all that is needed to automatically open the door



LOW ENERGY

Opens and closes the door at reduced energy and speed

► Specific Accessories

SBA: Articulated arm.

SPRINT BRAS: Three-section articulated arm for doors opening inwards, automation side.

SBS: Sliding arm.

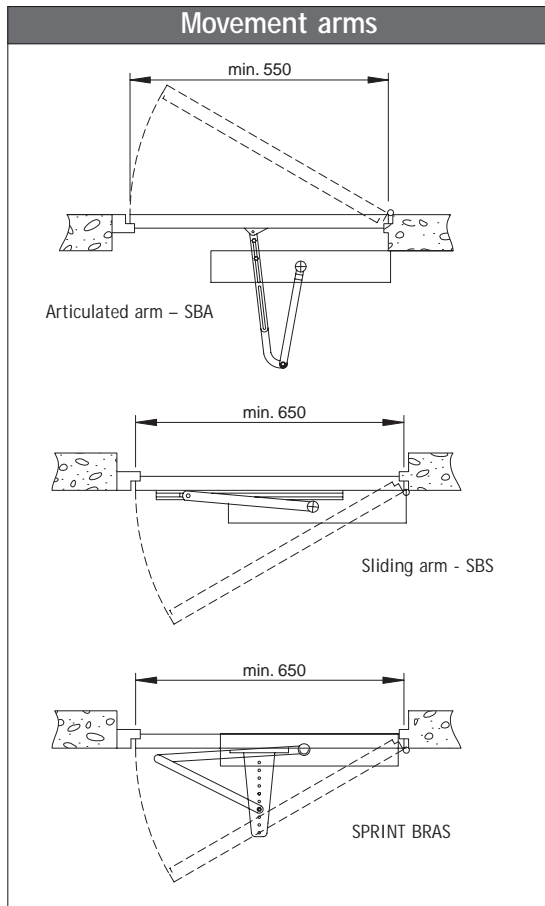

► Automation complementary accessories

Each automation system must be completed with control, monitoring and safety devices compatible with all system components and compliant with applicable standards.

► Facility programmers with or without key lock

► COM

These are new mechanically and digitally operated electronic programmers, designed to select and set the desired operating modes for one or more automatic doors.

These programmers can easily be used with either sliding or swing doors by simply replacing the front template, supplied as standard.

The type of automation is automatically detected as soon as it is connected.

► COM E

New and smart looking

COM E is the new digital electronic selector switch, designed to set up the 99 electronic control panel operating modes, in order to control one or more Wel automations.

The unit consists of a microcontroller, with front keypad and LED indicator. It may be surface or flush mounted on a wall, and has been designed to be compatible with standard square electrical switches and sockets.

Operating options

- COM E can be used to set up up to 4 doors in the same mode;
- Two COM E may be connected together on the same automation;
- COM EL is a practical and useful accessory used to key lock the automation from the outside, with matching look;
- TEL RC is the infrared beam receiver unit, which may be fitted inside the COM E selector switch, which allows the settings for the automation to be controlled by means of remote control TEL 2.

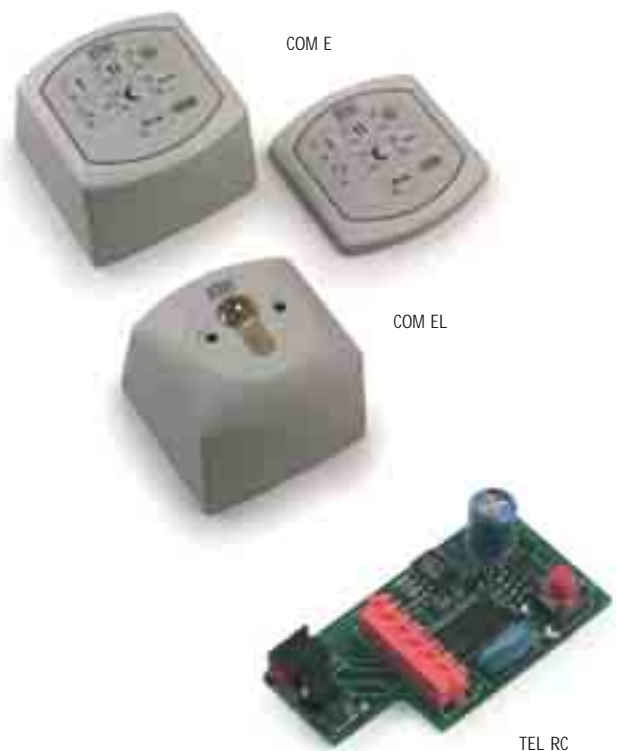

► COM H and COM K

They are new rotary programmers, used to set up the different operating modes of automatic doors. Available in two versions: handle (COM H) or key (COM K) operated, they are supplied with two interchangeable front panels, for sliding or swing doors.

The control unit is a 6 position, rotary electromechanical selector switch.

These units can also be surface or flush mounted on a wall, and have been designed to be compatible with standard square electrical switches and sockets.

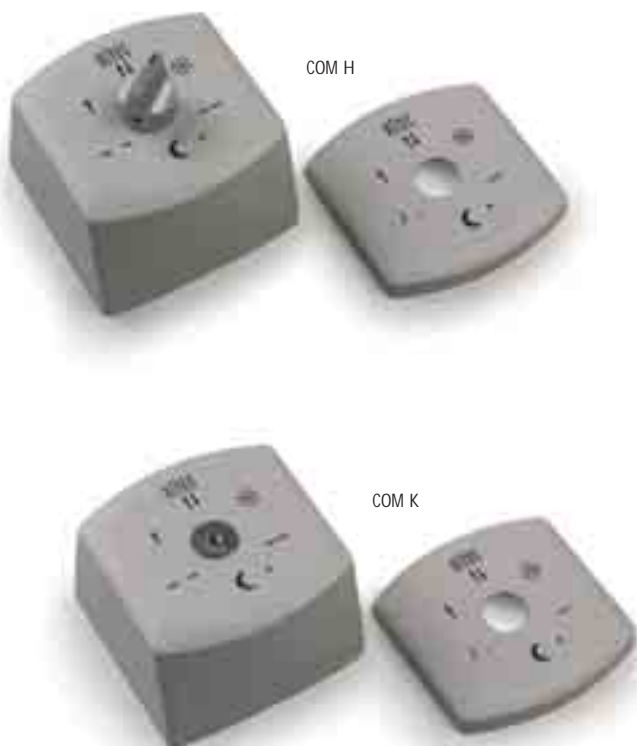

▶ Area Sensors

These are advanced electronic sensors detecting a person standing or going through a specific area in front of the entrance, which control door opening, and also ensure safety on passing through.

▶ Passive infrared sensors

They feature the following facilities (according to models):

- Sensitivity adjustment and opening selection;
- Opening range zoom adjustment.



▶ Microwave sensors

One- or two-way area sensor system, which may also be wall and ceiling mounted, by using a special mounting. Accurately detects motion.

Settings can also be remotely changed by means of a remote control.



▶ REM

▶ Active infrared barriers

REM are active area barriers to protect and/or detect people or objects. One or more infrared beams are emitted by the device and are reflected by an obstacle located in the detection area, which triggers the output contact.

The sensitivity is practically unaffected by the colour or structure of the object surface. The detection beam range and angle may be adjusted to meet all installation requirements.



▶ Safety photocells

They offer more control in obstacle detection. Practical and almost invisible, they may be fitted at different heights.

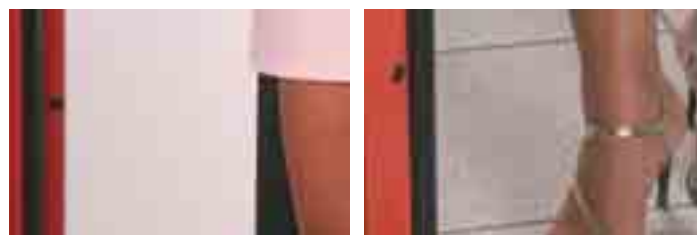

▶ Digital selector switches and keypads or key operated selector switches

They allow access only to authorised staff and can be easily installed in any outdoor or indoor environment. Two models are available: key operated and keypad operated, with vandal-proof combination.



▶ Touch operated sensors or transponder technology control sensors

They are fitted with buttons or code protected cards and are ideal to easily open entrances of companies or blocks of flats or for any site requiring authorised access only.



▶ Control pushbuttons

They allow users to open the door by lightly pressing them or touching them with their hand.

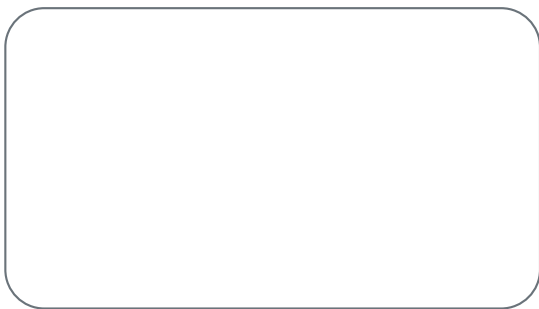

▶ Sensitive floor platforms

These platforms can be positioned under door mats, where they detect motion and automatically open the door.



▶ Standards

The system has been manufactured by using only DITEC manufactured accessories and safety devices.

All DITEC automations are affixed with the CE mark and are designed and manufactured in compliance with the Machinery Directive (98/37/EC), the Electromagnetic Compatibility Directive (89/336/EEC) and the Low Voltage Directive (73/23/EEC).

DITEC S.p.A. operates a policy of continuous development and reserves the right to make changes and improvements to their products. The technical data contained within this document is therefore not binding.

Further information can be found in our on-line technical manuals at: www.ditec.it



DITEC S.p.A.

Via Mons. Banfi, 3 - 21042 Caronno Pertusella (VA) - ITALY
Tel. +39 02 963911 - Fax +39 02 9650314
www.ditec.it - ditec@ditecva.com

DITEC BELGIUM
DITEC DEUTSCHLAND
DITEC ESPAÑOLA
DITEC FRANCE
DITEC SVIZZERA
DITEC AMERICA
DITEC CHINA

LOKEREN
OBERURSEL
ARENYS DE MAR
PALAISEAU
BALERNA
ORLANDO-FLORIDA-USA
SHANGHAI

Tel. +32 9 3560051
Tel. +49 6171 9141550
Tel. +34 937958399
Tel. +33 1 64532860
Tel. +41 91 6463339
Tel. +1 407 8880699
Tel. +86 21 62363861/2

Fax +32 9 3560052
Fax +49 6171 9141555
Fax +34 937959026
Fax +33 1 64532861
Fax +41 91 6466127
Fax +1 407 8882237
Fax +86 21 62363863

www.ditecbelgium.be
www.ditec-germany.de
www.ditecespanola.com
www.ditecfrance.com
www.ditecswiss.ch
www.ditecamerica.com
www.ditec.cn



ISO 9001
Cert. n° 0957